

# LARGE 200

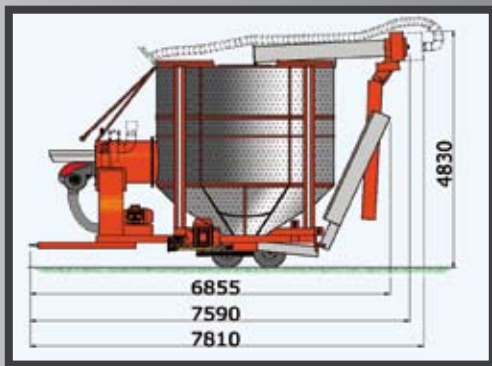
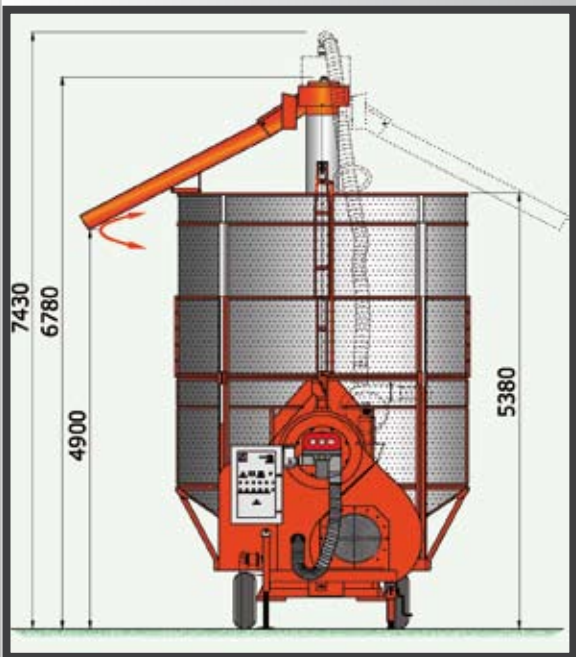

## TECHNICAL DATA

### Batch capacity

Tons wet maize 20 (28.5 m<sup>3</sup>)

### AVERAGE DAILY OUTPUT 24h in tons

Maize from 28% to 14% 100  
 Wheat/Barley from 20% to 15% 140  
 Oil seed rape from 14% to 9% 130

### POWER REQUIRED

Model Pto drive - Tractor min. size of HP 80  
 or single electric drive motor 45 kW (60 HP)

Model electric drive - Mains supply line of kW 35

Size main electric motor	(kW)	(HP)	Burner tripple stage as option	(kW)	(HP)
- fan	18.5	25		2.2	3
- central auger	18.5	25			
- filling auger	11.5	15			
- dust extractor	2.2	3			
- burner	1.5	2			

### FAN

Design centrifugal  
 Revs/Min. 1.450  
 Air flow m<sup>3</sup>/h max\* 50.000  
 \* The air flow volume refers to the fan as separate unit.

### BURNER

Diesel, Automatic twin stage (Gas as option)  
 Caloric power Kcal/h max. 950.000

Centre Auger Ø 350 mm, capacity tons/h 65  
 Filling Auger Ø 200 mm, capacity tons/h 45

### FUEL CONSUMPTION

Liters per ton of maize from 28% to 14% approx 15  
 Kcal per liter of water evaporated approx 900

N.B: All performance figures are largely depending of the ambient temperature, relative air humidity, maturity and cleanliness of crops to be dried

**A** Option with dust extractor  
Single roll discharging chute working in two positions

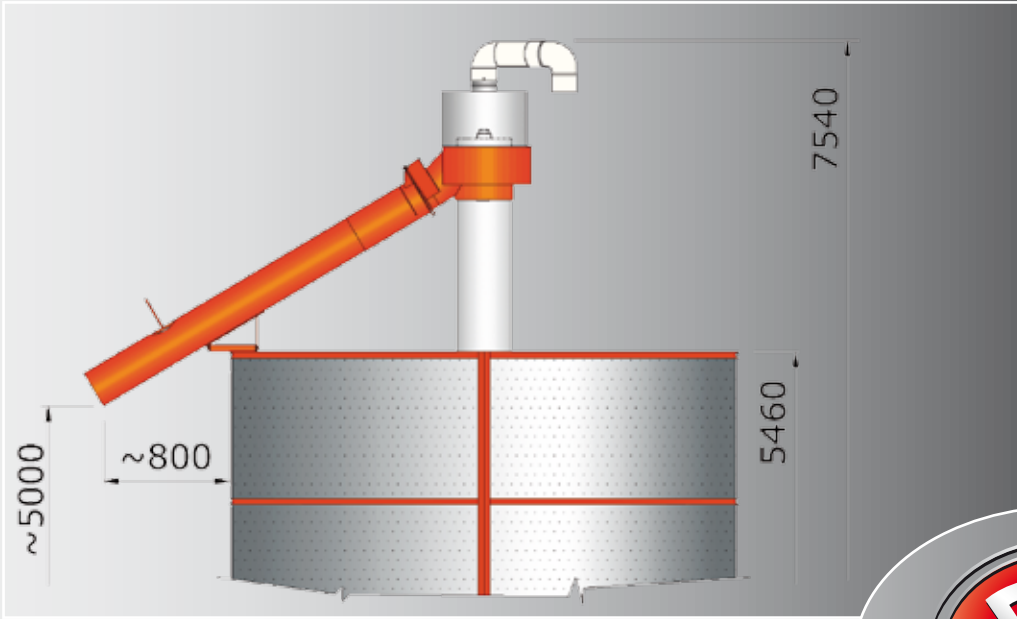

Alternative discharging options  
O/A hights refer to fix screen machine

**B** Option for lowest height with dust extractor  
Single fix discharging chute - double as option

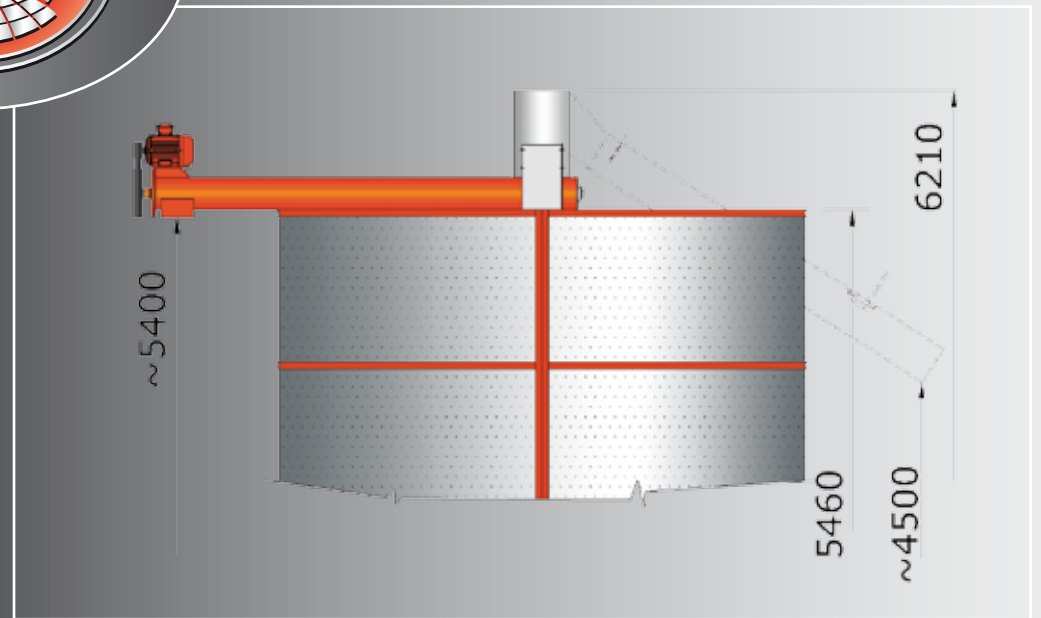
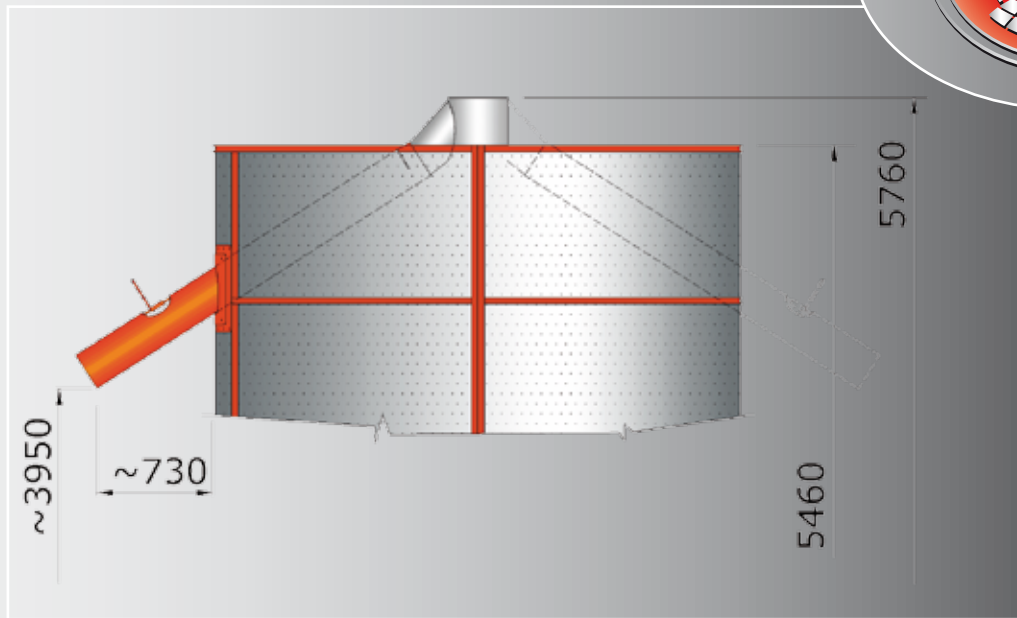
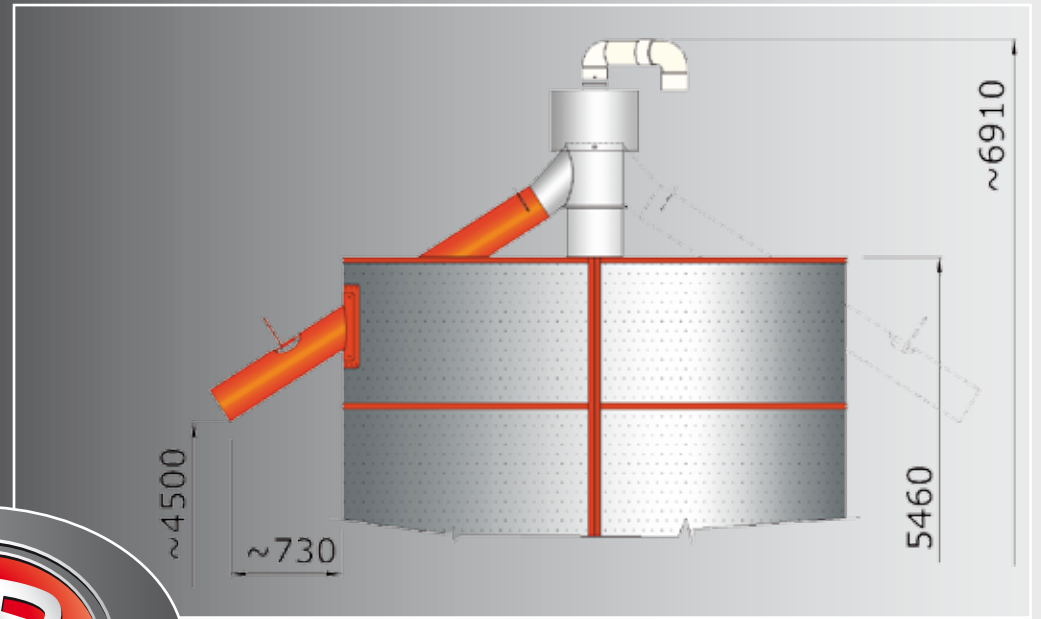

**C** Option for lowest height  
Single fix discharging chute - double as option

**LARGE 200**

**D** Option for horizontal discharging chute  
Single fix discharging chute, fix and motorized